

# Optimizing Energy Metabolism: A Novel Approach to Treat Ischemic Heart Disease

Metabolic therapies have recently emerged as a novel approach to treat myocardial ischemia. In this review, Dr. Keung and Dr. Lopaschuk will discuss the rationale for metabolic agents. The use of different metabolic agents for treatment of ischemic heart disease will also be examined.



**Wendy Keung, PhD; and Gary D. Lopaschuk, PhD**

Presented at the Global Conference on Heart Health and Disease, University of Manitoba, Winnipeg, Manitoba, October 12 to 15, 2006.

Myocardial ischemia results in a dramatic decrease in energy production by the heart. Traditional strategies for treating myocardial ischemia aim at increasing oxygen supply to the heart (*i.e.*, vasodilators, anti-platelet agents, anti-coagulants, thrombolytic therapy, angioplasty, coronary artery bypass surgery) or decreasing the oxygen demand of the heart muscle (*i.e.*,  $\beta$ -blockers, nitrates, angiotensin-converting enzyme [ACE] inhibitors). Metabolic therapies have recently emerged as a novel approach to treat myocardial ischemia. During and after ischemia, energy metabolism is altered, resulting in accelerated metabolism of glucose through glycolysis, but not the subsequent oxidation of the glycolytic byproduct, pyruvate. This increases myocardial lactate and H<sup>+</sup> production, leading to acidosis and a disruption of

*Metabolic agents act by optimizing energy metabolism through coupling glycolysis to pyruvate oxidation, resulting in a decrease in the severity of acidosis in the myocardium.*

ion homeostasis. Metabolic agents act by optimizing energy metabolism through coupling glycolysis to pyruvate oxidation, resulting in a decrease in the severity of acidosis in the myocardium.

## *Energy metabolism in the ischemic heart*

Myocardial ischemia occurs when there is not enough oxygen supply to promote adequate myocardial adenosine triphosphate (ATP) production to meet the demands of the heart at a given heart rate, afterload and inotropic state. Coronary artery disease (CAD) patients often have sufficient coronary blood flow and myocardial oxygen consumption at rest, but do not have a normal increase in coronary flow in response to greater demand for contractile power where greater oxygen demand is required. This mismatch between coronary flow and demand for oxygen occurs with physical exercise or adrenergic stimulation, resulting in insufficient aerobic ATP synthesis. This condition is referred to as “demand-induced ischemia.” It has been suggested that there is a causal link between lactate production by the myocardium, ST segment changes and angina.<sup>1</sup> Ischemia-induced chest pain has also been suggested to be the results of:

- ATP breakdown,
- adenosine formation and efflux and

## Optimizing Energy Metabolism

- its stimulation of cardiac sensory afferent neurons.<sup>2</sup>

Changes in ST segments of the ECG have also been suggested to be related to the opening of ATP-sensitive potassium channels in response to ATP depletion.<sup>3</sup>

### Ischemia-induced increases in the rate of glycolysis

During moderate ischemia, there is a reduction in aerobic formation of ATP in the mitochondria. The decrease in ATP formation leads to:

- a rapid stimulation of glycolysis,

- glucose uptake and
- a breakdown of tissue glycogen.

During severe ischemia, sources of ATP production, other than glycolysis, cease. Due to the low oxygen consumption, pyruvate produced by glycolysis is not oxidized in the mitochondria, but rather is reduced to lactate in the cytosol. Thus, during ischemia the myocardium switches from a net consumer of lactate to a net producer of lactate. As lactate accumulates in the cell, the pH in the cell also declines.<sup>4</sup> This occurs as the increase in glycolytic rate results in anaerobic hydrolysis of ATP and the production of excess cytosolic protons,<sup>5-7</sup> resulting in intracellular acidosis. The

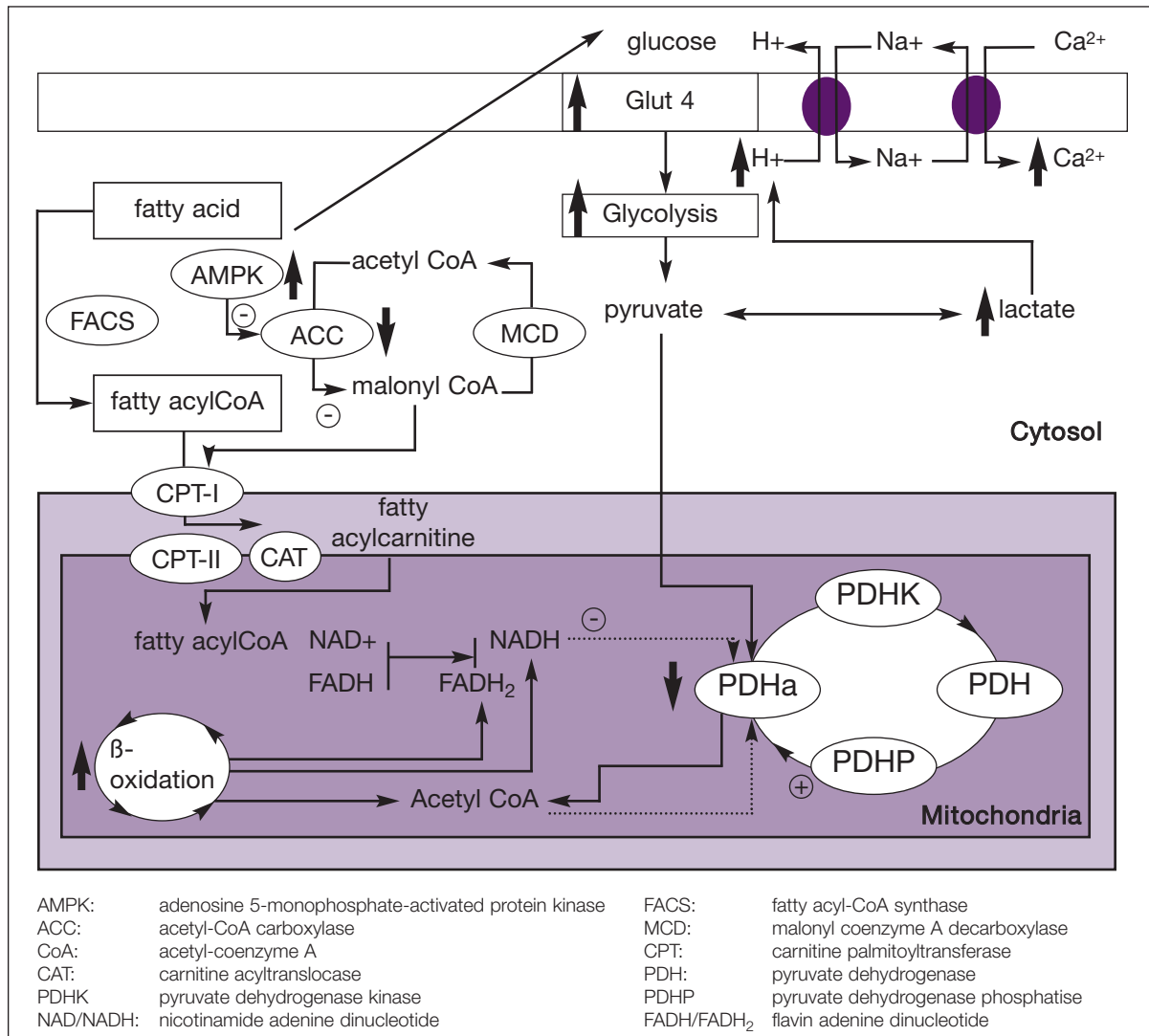

Figure 1. Myocardial energy metabolism during ischemia.

excess  $H^+$  are then extruded from the cytosol in exchange for other cations, via cation exchangers.<sup>8</sup> This leads to an increase in intracellular  $Na^+$  and  $Ca^{2+}$  overload and ultimately a decrease in cardiac efficiency as re-establishing homeostasis of protons,  $Na^+$  and  $Ca^{2+}$ , requires the use of ATP.<sup>8</sup>

### *Predominance of fatty acid oxidation for mitochondrial oxidative metabolism during ischemia*

During ischemia, mitochondrial oxidative metabolism decreases in proportion to the decrease in oxygen supply. This includes a decrease in both fatty acid and pyruvate oxidation (Figure 1). Despite the fact that there is an increase in lactate and  $H^+$  production from glycolysis during ischemia, pyruvate oxidation is low and during moderate ischemia, fatty acid oxidation predominates as a source of fuel.<sup>9-11</sup> This is due to both an increase in the levels of fatty acids to which the heart is exposed during ischemia, as well as to alterations in the subcellular control of fatty acid oxidation. During ischemia, Adenosine 5-monophosphate (AMP)-activated protein kinase (AMPK) is rapidly phosphorylated and activated.<sup>12-14</sup> The increase in AMPK phosphorylation promotes glucose uptake and glycolysis,<sup>15-17</sup> as activation of AMPK promotes the translocation of glucose transporter-4 (GLUT4) to the sarcolemma<sup>18</sup> and activates phosphofructokinase-2<sup>17</sup> which produces fructose 2, 6-bisphosphate, a potent stimulator of glycolysis. However, activation of AMPK also leads to the phosphorylation and inactivation of acetyl-coenzyme A carboxylase (ACC) (Figure 1).<sup>19,20</sup> This leads to a decrease in the production of malonyl-CoA, a potent endogenous inhibitor of carnitine palmitoyltransferase-1 (CPT-I).<sup>21,22</sup> The decrease in inhibition of CPT-I leads to increased rates of fatty acid oxidation. High rates of fatty acid  $\beta$ -oxidation, in turn, inhibits pyruvate oxidation. Thus, during ischemia, activation

of AMPK could potentially result in fatty acid vs. glucose dominating as the source of residual oxidative metabolism.

### *Increased rate of fatty acid oxidation during reperfusion of ischemic myocardium*

During reperfusion of previously ischemic myocardium, when coronary flow is resumed, contractile function in the reversibly injured myocardium will recover once energy production is restored and cytosolic  $Ca^{2+}$  levels normalized. The rates of fatty acid oxidation also increase. This is due to the high plasma concentration of fatty acid<sup>23-25</sup> as a result of the body's stress-induced mechanisms during ischemia, as well as the persistent activation of AMPK activity,<sup>12-13</sup> which consequently leads to a decrease in ACC activity and a decrease in malonyl-CoA production. As a result of this high rate of fatty acid oxidation, the rate of pyruvate oxidation remains low.<sup>26-30</sup> This is due to the increase in the mitochondrial acetyl-CoA/malonyl-CoA and nicotinamide adenine dinucleotide (NADH/NAD<sup>+</sup>) ratios caused by excessive rates of fatty acid oxidation, which leads to the activation of pyruvate dehydrogenase kinase and hence inactivation of pyruvate dehydrogenase (PDH).<sup>31</sup> The decrease in pyruvate oxidation causes an impaired coupling of glycolysis to pyruvate oxidation, leading to an increase in the production of  $H^+$  ions similar to what is seen during ischemia.<sup>32</sup> The clearance of these  $H^+$  ions during reperfusion contributes to the impaired recovery of

#### **About the authors..**

**Dr. Keung** is a Post-Doctoral Fellow, Department of Pediatrics, University of Alberta, Edmonton, Alberta.

**Dr. Lopaschuk** is the Scientific Director, Mazankowski Alberta Heart Institute and Professor, Department of Pediatrics, University of Alberta, Edmonton, Alberta.

mechanical function.<sup>26,27,29</sup> This decrease in cardiac efficiency results in less systolic shortening and less Ca<sup>2+</sup> uptake by the sarcoplasmic reticulum.<sup>6,9</sup>

### *Metabolic agents used to treat myocardial ischemia*

A fundamental metabolic consequence of ischemia/reperfusion injury to the heart is a decrease in cardiac efficiency due to increased rate of fatty acid oxidation and the decreased rate of oxidative pyruvate metabolism. Therefore, one approach to treat ischemic heart disease is to minimize the impairment of oxidative pyruvate metabolism by inhibiting fatty acid oxidation, or by directly stimulating pyruvate oxidation in the mitochondria (Figure 2).<sup>33,34</sup>

*Trimetazidine is one example of a “partial inhibitor” of fatty acid  $\beta$ -oxidation, as maximum inhibition of 3-KAT by trimetazidine is approximately 70%.*

### *Inhibitors of fatty acid oxidation*

As discussed, high fatty acid oxidation rates markedly decrease pyruvate oxidation. Therefore, one approach to increase pyruvate oxidation is to inhibit fatty acid oxidation.

#### *Direct inhibitors of fatty acid $\beta$ -oxidation*

One class of agent that inhibits fatty acid oxidation is direct  $\beta$ -oxidation inhibitors. These agents work by inhibiting  $\beta$ -oxidation directly, decreasing the production of NADH and acetyl-CoA, which are strong inhibitors of pyruvate dehydrogenase. This decreases the production of lactate

and protons, which helps maintain a more normal pH during ischemia.

### *Trimetazidine*

Classic pharmacotherapy for demand-induced ischemia aims at restoring the balance between ATP synthesis and breakdown by increasing the oxygen delivery with long-acting nitrates or Ca<sup>2+</sup> channel antagonists, or by decreasing cardiac power by reducing BP and heart rate with  $\beta$ -blocker or Ca<sup>2+</sup> channel antagonists.<sup>35</sup> Trimetazidine was the first drug to be marketed clinically as a “cellular antianginal agent,” with a mechanism that targets to optimize the metabolism of the myocardium.

In animal studies, trimetazidine has been shown to inhibit the rate of palmitoylcarnitine oxidation by 57% in isolated rat cardiomyocytes<sup>36</sup> at a concentration of 100  $\mu$ M. It was found that trimetazidine did not directly affect the rates of pyruvate, glutamate or citrate oxidation. More recent studies with isolated working rat hearts demonstrated that trimetazidine reduces the rate of fatty acid oxidation and increases pyruvate oxidation by inhibition of the long chain 3-keto-acyl-coenzyme A thiolase (3-KAT), the enzyme catalyzing the last step in the four step  $\beta$ -oxidation pathway.<sup>37,38</sup> This inhibition of long chain 3-KAT leads to an indirect stimulation of PDH and hence an increase in pyruvate oxidation.<sup>37</sup> In vivo studies have also shown that administration of trimetazidine decreases ST-segment elevation for regionally ischemic rabbit hearts and reduces infarct size in rabbit and dog models of cardiac ischemia.<sup>39</sup>

Trimetazidine is one example of a “partial inhibitor” of fatty acid  $\beta$ -oxidation, as maximum inhibition of 3-KAT by trimetazidine is approximately 70%.<sup>34,37</sup> At clinical concentrations, the inhibition of 3-KAT is approximately 20% to 40%.<sup>34</sup> Initial double-blind trials showed that trimetazidine improve the ergometric exercise capacity and total work output of patients with effort angina, increasing the time to 1 mm ST-segment depression relative to placebo.<sup>40</sup>

Multicenter trials of trimetazidine by a European collaborative working group demonstrated that the anti-anginal efficacy of trimetazidine is equivalent to that of propranolol and nifedipine.<sup>41,42</sup> Trimetazidine, at an oral dose of 20 mg t.i.d., improves left ventricular (LV) function in patients with ischemic cardiomyopathy without concomitant changes in heart rate and BP and without appreciable side-effects, suggesting that the improved cardiac function is due to cytoprotection unrelated to hemodynamic effects.<sup>43</sup> In a meta-analysis of 12 randomized, double-blind trials evaluating trimetazidine conducted between 1985 and 2001, trimetazidine was found to be effective in lowering the frequency of angina attacks and to significantly improve time to 1 mm ST depression when compared to control. The effects of trimetazidine were similar to those of other anti-anginal agents.<sup>44</sup>

Trimetazidine has also been shown to provide additional benefits when used in combination with classic hemodynamic agents. In patients with CAD, the combination of trimetazidine with diltiazem has been shown to:

- reduce the number of ischemic attacks,
- prolong the time to 1 mm ST depression,
- increase the time to angina during exercise as well as
- increase the maximum work at peak exercise.<sup>45,46</sup>

In the second Trimetazidine in Poland (TRIM-POL II) study, patients with stable angina insufficiently controlled by  $\beta$ -blocker monotherapy showed significant improvement in all ergometric and clinical parameters when trimetazidine was added to metoprolol as combination treatment.<sup>47</sup> A recent study of trimetazidine (30 mg b.i.d.) modified release in symptomatic patients with a

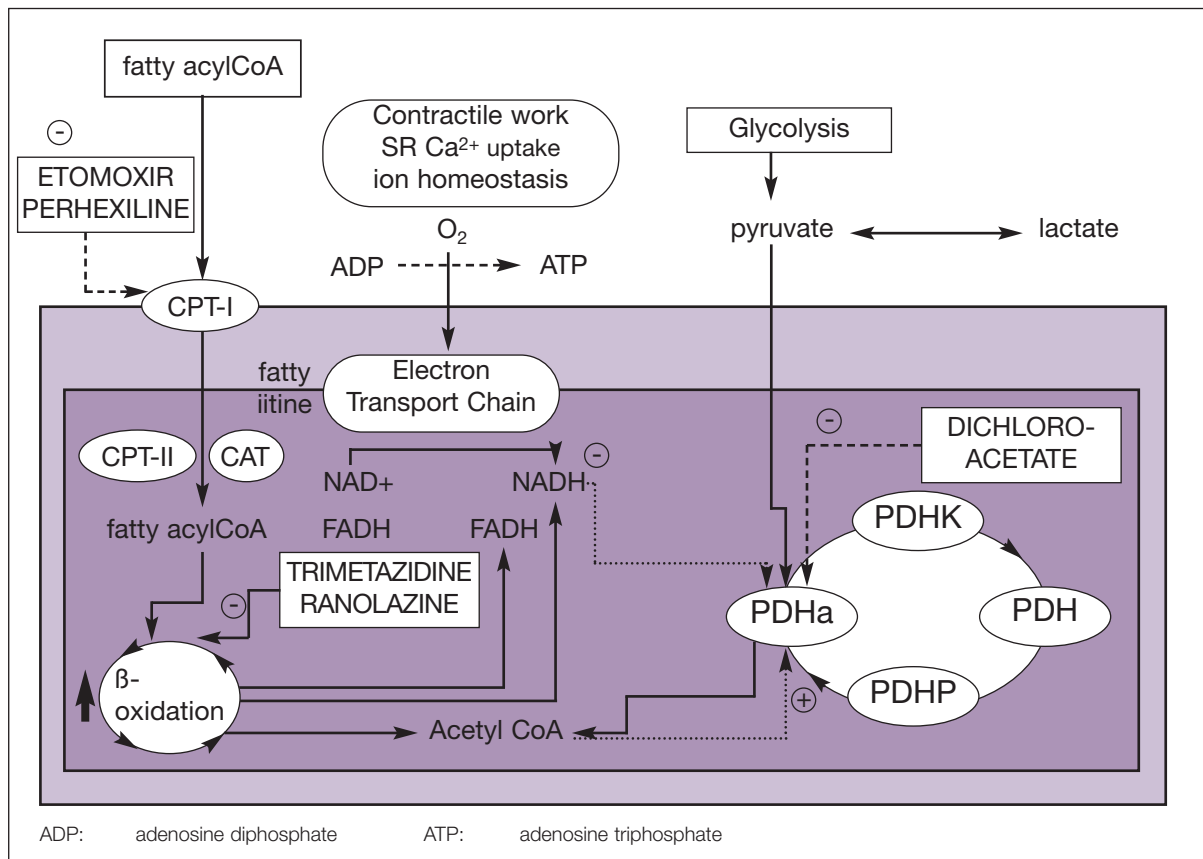

Figure 2. The site of action of different cardiac metabolic agents.

positive exercise tolerance test, despite background therapy with atenolol, also showed a significant increase in the angina and ischemic thresholds when trimetazidine was added to atenolol as treatment.<sup>48</sup> There is also evidence for the use of trimetazidine in cardiac rehabilitation in patients with CAD. A recent study indicates that the combination of trimetazidine with exercise training potentiates the effect of exercise training and improves functional capacity and left ventricular systolic function.<sup>49</sup>

*Ranolazine, like trimetazidine, is a partial inhibitor of fatty acid oxidation and inhibits 60% of fatty acid oxidation at maximum doses.*

### *Ranolazine*

Ranolazine is an active piperazine derivative that was patented in 1986. While the exact molecular mechanism for its antianginal action is still under debate, ranolazine has been demonstrated to enhance myocardial pyruvate oxidation and decrease fatty acid oxidation.<sup>50-52</sup> Ranolazine, like trimetazidine, is a partial inhibitor of fatty acid oxidation and inhibits 60% of fatty acid oxidation at maximum doses.<sup>53</sup> Treatment with ranolazine results in an increase in PDH, secondary to the inhibition of  $\beta$ -oxidation.<sup>50-52</sup> Like trimetazidine, ranolazine does not directly inhibit:

- PDH kinase,
- PDH phosphatase,
- PDH catalytic activity,<sup>50</sup> or
- CPT-I activity.<sup>54</sup>

The indirect increase in PDH activity by ranolazine leads to an increase in the amount of pyruvate entering the tricarboxylic acid (TCA) cycle, leading to a decrease in the uncoupling of glycolysis from pyruvate oxidation, hence a

decrease in lactate and  $H^+$  production, decreasing intracellular  $Na^+$  and  $Ca^{2+}$  overload.<sup>32,55</sup>

In isolated hearts, the concentrations of ranolazine that produces positive effects of  $\beta$ -oxidation inhibition are much higher than the therapeutic plasma concentrations in human clinical trials of  $> 10 \mu\text{mol/L}$ .<sup>51,52</sup> At a concentration of  $20 \mu\text{mol/L}$ , ranolazine improves post-ischemic cardiac function in isolated working rat hearts perfused with a high concentration of free fatty acids. An alternative mechanism of action for ranolazine proposed is its ability to reduce calcium overload by inhibiting late sodium current ( $IN_a$ ). The late  $IN_a$  is an inward current caused by the influx of  $Na^+$  during the plateau of the action potential. This late  $IN_a$  is known to be increased in ischemia. The rise in intracellular  $Na^+$  triggers an increase in influx of calcium via the  $Na^+/Ca^{2+}$  exchanger, resulting in intracellular  $Ca^{2+}$  overload. Ranolazine, at therapeutically relevant concentrations ( $10 \mu\text{mol/L}$ ), has been shown to selectively inhibit late  $IN_a$  without affecting the fast sodium current or the  $Na^+/H^+$  and  $Na^+/Ca^{2+}$  exchangers,<sup>57</sup> preventing or reversing the induced mechanical dysfunction in ischemia.<sup>58</sup>

Ranolazine is available in an immediate-release form and also in a sustained-release form. Early studies with the immediate-release form provided evidence for anti-ischemic/anginal properties. Ranolazine, dosed twice daily, as either monotherapy<sup>59,60</sup> or add-on therapy,<sup>61</sup> demonstrated improvements in exercise treadmill time and time-to-onset of angina compared with placebo.<sup>59-61</sup> A recent randomized, double-blind, placebo-controlled cross over study of 158 patients with angina given ranolazine 400 mg t.i.d. demonstrated that, compared with placebo, ranolazine and atenolol can both significantly increase:

- exercise time,
- time to angina and
- time to 1 mm ST segment depression.<sup>62</sup>

Sustained-release ranolazine has also been demonstrated to be an effective treatment for stable angina in several clinical trials. The

Monotherapy Assessment of Ranolazine in Stable Angina (MARISA) study tested a three fold dose range of ranolazine at 500 mg, 1000 mg and 1500 mg b.i.d. An exercise test was conducted at 12 hours after dose and four hours after dose at the end of each treatment week. All three doses resulted in a significant increase in exercise duration at trough compared with placebo in a dose-dependent manner, with a plateau at 1000 mg b.i.d.<sup>63</sup> Ranolazine has also shown beneficial effects when used in combination with other antianginal agents. The Combination Assessment of Ranolazine in Stable Angina (CARISA) trials tested the effect of sustained-release ranolazine 750 mg or 1,000 mg b.i.d. for 12 weeks in patients on atenolol (50 mg q.d.), diltiazem (180 mg q.d.) or amlodipine (5 mg q.d.). The results showed that compared with placebo, ranolazine significantly increases symptom-limited exercise duration from a mean of 24 seconds to 34 seconds. The mean number of weekly anginal attacks and nitroglycerin use over the 12-week treatment period with ranolazine was also significantly reduced in a dose-dependent fashion. While rebound worsening of the patient's underlying angina was not seen with abrupt withdrawal of ranolazine at the end of the 12 week treatment, the therapeutic effect of ranolazine on exercise duration was no longer seen within two days after withdrawal of the therapy.<sup>64</sup> A third trial of sustained-release ranolazine in chronic angina, the Efficacy of Ranolazine in Chronic Angina (ERICA) trial, aimed to determine if ranolazine improved angina in stable coronary patients with persisting symptoms despite taking the maximum recommended dose of amlodipine. It differed from the earlier two studies in that the primary efficacy variable for ERICA was the average number of angina attacks per week, rather than symptom-limited exercise duration. Treadmill-induced angina and ischemic ST-segment depression were also not required as entry criteria. The mean number of angina episodes per week was significantly decreased in the ranolazine group compared to

placebo after six weeks of treatment. The mean nitroglycerin use per week was also significantly decreased when compared to the placebo group. The magnitude of symptomatic improvement was greater in patients with more anginal attacks per week at baseline.<sup>65</sup> A new multinational endpoint-driven trial on ranolazine, the Metabolic Efficiency With Ranolazine for Less Ischemia in Non-ST-Elevation Acute Coronary Syndrome (MERLIN TIMI 36) is expected to complete enrollment in 2006. The primary end point of this trial is the time to first occurrence of any element of the composite of cardiovascular death, MI, or recurrent ischemia. Patients are randomized 1:1 in a double blind design to intravenous infusion followed by 1,000 mg oral ranolazine ER b.i.d. or match placebo until the end of the study.<sup>66</sup>

### *Inhibitors of mitochondrial carnitine palmitoyltransferase-I*

Carnitine palmitoyltransferase-I is the first step for mitochondrial oxidation (Figure 1). It catalyzes the conversion of long-chain acyl-CoA to long-chain acylcarnitine, which is transported into the mitochondrial matrix and reconverted back to long-chain acyl-CoA to be metabolized by the  $\beta$ -oxidation pathway. Pharmacological blockade of CPT-I can decrease fatty acid oxidation, reduce acetyl-CoA level and NADH, leading to the increase in activities of pyruvate dehydrogenase and phosphofructokinase, as well as the rate of glycolysis.

### *Perhexiline*

Perhexiline was first introduced in the 1970s as a treatment for stable angina and refractory stable angina. It has been shown to decrease the frequency of anginal attacks and the use of glyceryl trinitrate tablets.<sup>67,68</sup> The antianginal effects of perhexiline have also been demonstrated to be superior to those of  $\beta$ -adrenoceptor blocking agents.<sup>69,70</sup> Perhexiline has been thought to act as a vasodilator, or a  $Ca^{2+}$  antagonist.<sup>71,72</sup> However, it

is now known that perhexiline acts via the inhibition of CPT-I and cardiac fatty acid oxidation.<sup>73-75</sup> In the 1980s, the use of perhexiline started to decline as reports of adverse effects surfaced. Major side-effects included:

- the development of neuropathy,
- hepatotoxicity,
- hypoglycemia and
- weight loss.<sup>76</sup>

Perhexiline-induced neuropathy may result from a genetic variation in the metabolism of the drug.<sup>77</sup> It has subsequently been determined that maintaining a plasma concentration range between 0.15 mg/L and 0.6 mg/L enables safe use of the drug without compromising efficacy.<sup>78</sup> The neuropathy and hepatotoxicity may be due to the systemic inhibition of CPT-I when plasma perhexiline levels exceeded the recommended range.

### *Etomoxir*

Etomoxir was initially developed as an anti-diabetic drug.<sup>79</sup> Results from animal studies showed that it has potential for being a metabolic antianginal agent, although randomized controlled clinical trials have yet to be conducted to confirm the claims. In fatty acid-perfused ischemic rat hearts, etomoxir has been shown to reduce oxygen consumption during ischemic recovery and to prevent myocardial function depression by inhibiting the effect of CPT-I in the heart.<sup>80,81</sup> One small open-labelled clinical trial in 15 New York Heart Association Class II-III heart failure patients showed that following three months of etomoxir, 80 mg q.d., there is improvement in:

- left ventricular ejection fraction,
- cardiac output at peak exercise and
- clinical status.<sup>82</sup>

### *Direct stimulators of pyruvate oxidation*

Moderate myocardial ischemia causes an accelerated rate of glycolysis, glucose uptake, as well as tissue glycogen breakdown, resulting in lactate

production and accumulation in the cell. Therefore, one approach to decrease lactate accumulation is to directly activate PDH.<sup>32,83</sup> Activating PDH increases pyruvate oxidation, resulting in better coupling with glycolysis and a decrease in lactate production and H<sup>+</sup> accumulation.

### *Dichloroacetate*

Dichloroacetate (DCA) activates pyruvate metabolism<sup>29,84</sup> by inhibiting PDH kinase and preventing phosphorylation of PDH.<sup>85</sup> DCA has also been shown to inhibit fatty acid oxidation by increasing acetyl-CoA groups in the cytosol.<sup>84</sup> Acetyl-CoA can then be converted to malonyl-CoA in the cytosol to inhibit the CPT-I, resulting in reduced fatty acid uptake into the mitochondria.<sup>84,85</sup> In rat models, DCA has been shown to dramatically improve recovery of mechanical function following ischemia.<sup>29,86,87</sup>

In humans, acute administration of DCA has been shown to increase left ventricular stroke volume without changes in heart rate in nine patients with coronary heart disease.<sup>88</sup> Despite these beneficial effects, DCA has not been in widespread use clinically, as it is not a potent drug and blood levels at the mM range have to be achieved to increase myocardial pyruvate oxidation. Its short half-life, after administration, is also a factor limiting its clinical use.<sup>89</sup>

### *Conclusions*

Contractile function and cardiac efficiency are compromised during and following myocardial ischemia. Experimental data supports the notion that shifting energy substrate preference, from fatty acid metabolism to glucose metabolism, is an effective approach to treat ischemia. Both animal and clinical studies support the use of metabolic agents, both as monotherapy or in combination with other classical anti-ischemic agents, as treatment for myocardial ischemia. 

For references, please contact [cardio@sta.ca](mailto:cardio@sta.ca)